IKA Service-Manual

Shaker / Schüttler

MS 1 S1

No. L001501



IKA®

IKA – Werke GmbH & Co. KG
Janke & Kunkel-Str. 10
D - 79219 Staufen

Phone: 0049 (0)7633 831 139 / 202
Fax: 0049 (0) 7633 500 212
E-Mail: service@ika.de
Internet: www.ika.de

Type: **MS 1 S 1 IKA Minishaker**Item No.: **L001501**

Voltage: 115V~ 50/60Hz

IKA® Service-Manual

Date: 27-FEB-2007

SZ: L001500SZf

Pos	Item No	Bezeichnung	Description	Technical data	Bemerkung	Remark
10	2809400	DREHPOTENTIOMETER	POTENTIOMETER	k 50,00		
20	L001011	TRAFO	TRANSFORMER	Sec : 12V/1,5A		
30	L001030	WIPPSCHALTER	ROCKER SWITCH	V 125/250A 4,0		
40	L001060	GERÄTESICHERUNG	FUSE 0,40 T	A 0,400V 250 5x20	ersetzt durch: 2008600	replaced by: 2008600
40	2008600	GERÄTESICHERUNG 0,63A T	FUSE 0,63A T	A 0,630V 250M5x20 T		
60	L001090	BLP	PCB		ersetzt durch: 3507300	replaced by: 3507300
60	3507300	BLP	PCB			
90	L001380	FRONTSCHILD	FRONT PLATE	MS1		
120	L001240	MANSCHETTE	SLEEVE			
130	L001260	Standardaufsatz	Standart attachment	MS 1.1		
140	L001290	O-RING	O-RING	75,92x 1,78		
150	L001320	GUMMIPLATTE T	RUBBER SHEET T	55,0x 25,0x 2,5		
155	L001330	GUMMIPLATTE P	RUBBER SHEET P	98,0x 12,0x 1,6		
170	L001340	GUMMIFUSS	VIBRATING FOOT	D 17,0xd 4,3 H 6		
195	0389900	FLACHSTECKER	FLAT CONNECTION	Ms 6,3x0,8 90°		
200	L001170	BLATTFEDER	COACH SPRING			
210	L001390	MOTOR kpl.	MOTOR complete			
220	L001410	WIPPE kpl.	ROCKER, complete			
230	L001870	SCHILD	LABEL	Touch / Platform		
235	3422700	SCHUTZKAPPE	PROTECTION CAP	bearbeitet		
250	L001440	SPANNROLLE kpl.	BT-ROLLER			
260	2472100	BEDIENKNOPF Poti	OPERATING KNOB Poti	D 33,3d 6 PDX-M96070		
270	2279700	EINBAUSTECKER T65°C	RECEPTACLE	250V 6A sw		
290	L001460	DRUCKFEDER	COMPRESSION SPRING			
300	L001810	RASTKNOPF	PLUNGER			
310	L001820	BLATTFEDER	COACH SPRING			
1902	L001850	Reagenzglaseinsatz	Test tube insert	MS 1.32		
1903	L001490	Reagenzglasaufnahme	Test tube attachment	MS 1.3		
1904	L001280	Mikrotiterplattenaufs.	Microtiter plate attachment	MS 1.4		
1905	L001540	Einhandeinsatz	One-hand insert	MS 1.21		

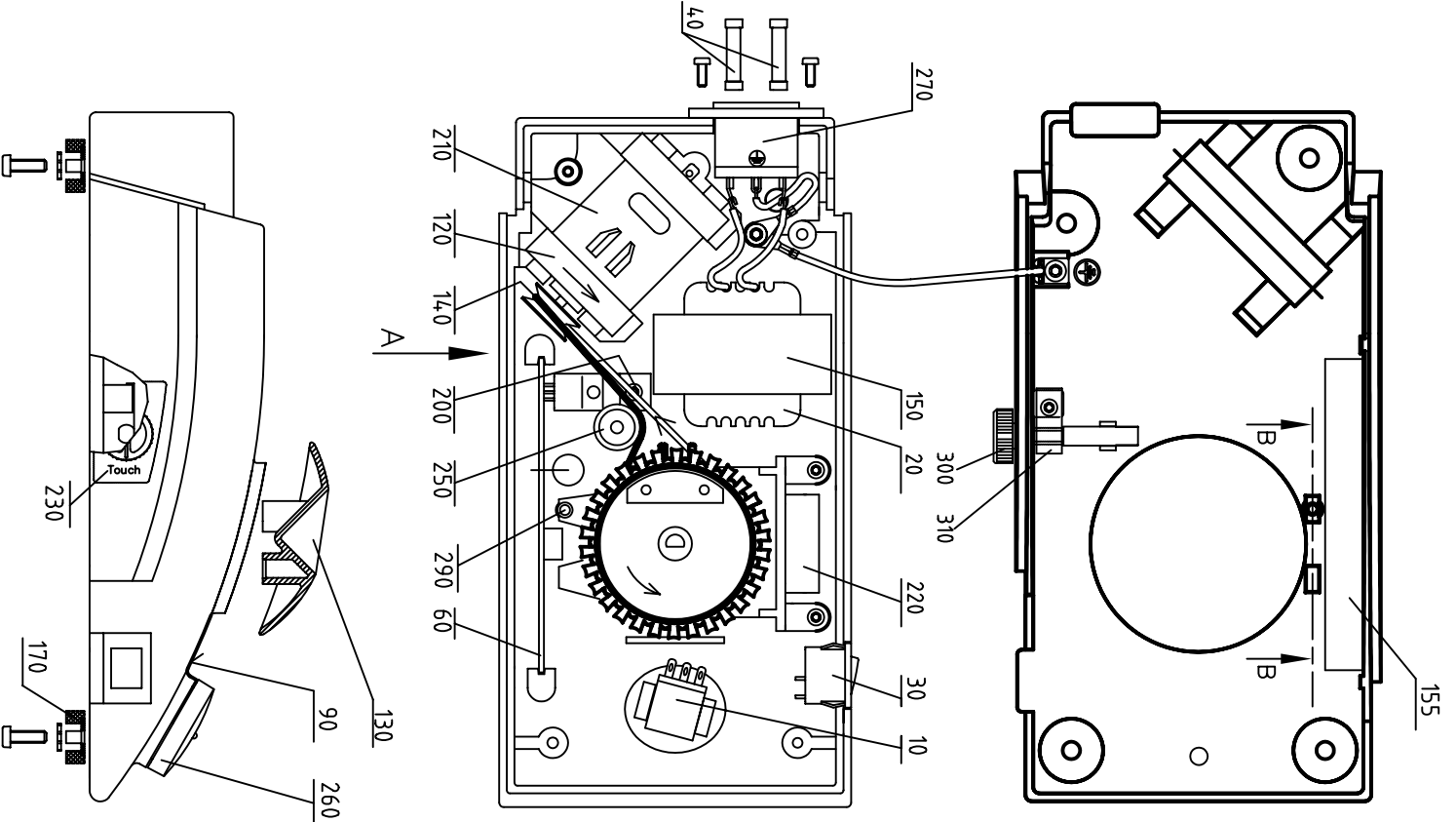

B-B

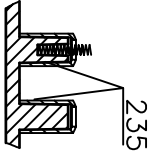

Mittellieferte Aufsätze/ provided attachment

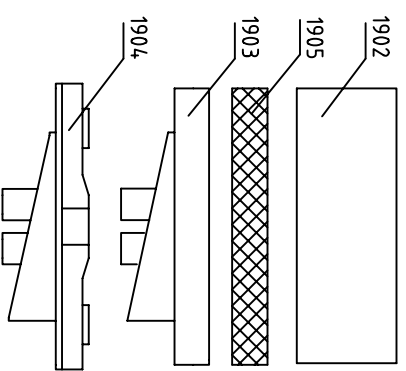

"A"

Motorkabelverlegung / laying of motor cables

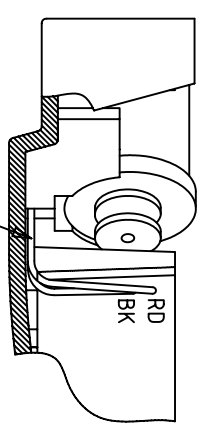

Achtung!
Kabel bei Montage nicht einquetschen
Attention!
Do not squash cable when assembling the bottom

Verdrahtungsplan /
Wiring diagram

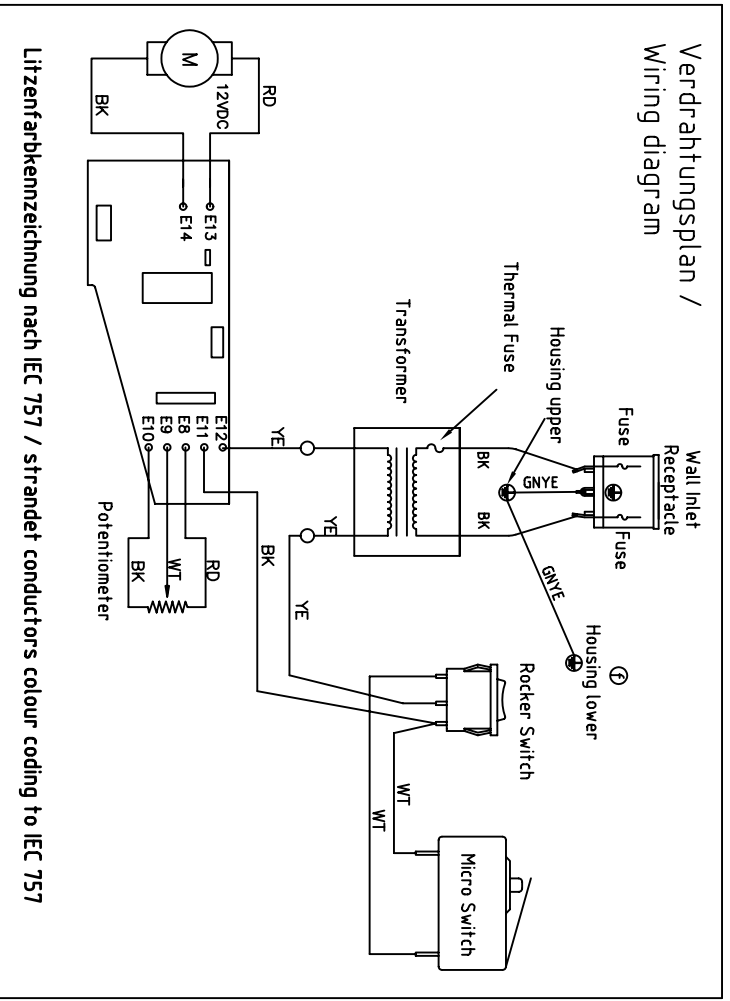

Litzenfarbkennzeichnung nach IEC 757 / strandet conductors colour coding to IEC 757